

AG Optical Systems LLC

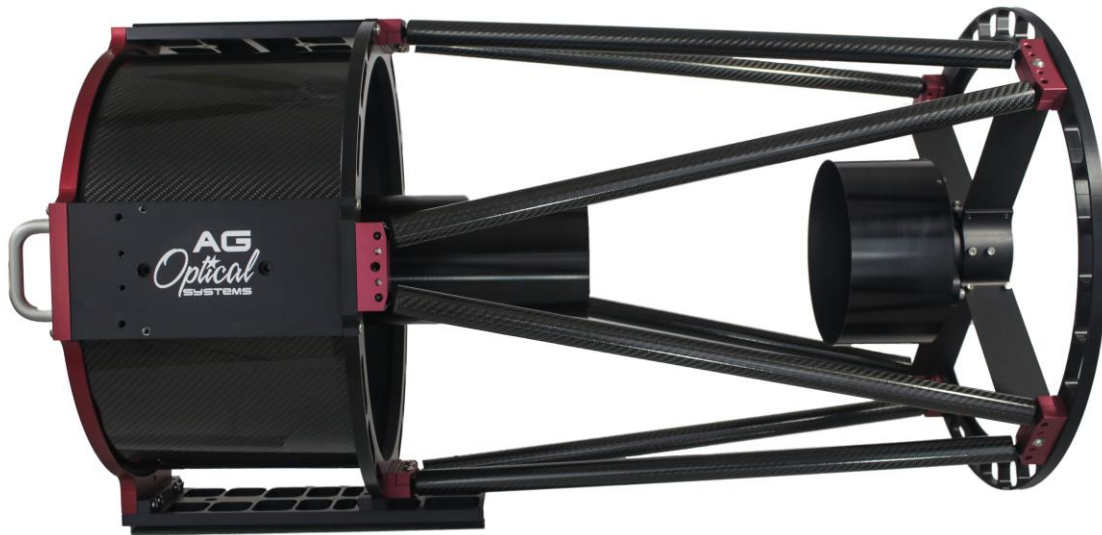

Convergent, Imaging Harmer Wynne, Imaging Dall Kirkham Astrograph Manual

Version 3 2019

Please read through the entire manual before making any adjustments to your AG Optical Systems telescope.

Table of Contents

1. Introduction
2. System Specifications
3. Initial Assembly
4. Collimation
5. Care and Cleaning
6. Cooling Fan Operation
7. AG Optical Systems Thermal Control System
8. Warranty



M81 by Dan Wilson, AG Optical Systems 17" iDK

Introduction

Thank you for your purchase of an AG Optical Systems telescope. Your telescope has been carefully crafted using modern manufacturing technologies and high-tech materials to provide outstanding, reliable performance. As with any high quality optical instrument, care must be taken in the use and maintenance of the telescope to ensure it performs to its maximum potential. Should you have any questions that are not addressed by the contents of this manual please contact AG Optical Systems.

System Specifications

System Focal Ratio: Convergent F5, Imaging Harmer Wynne F3.9, Imaging Dall Kirkham F6.7 (nominal)

Primary Mirror Substrate: Low expansion borosilicate (iHW, Convergent), quartz (iDK)

Primary Mirror Coating: Enhanced aluminum

Secondary Mirror Substrate: Optical Grade Fused Quartz

Secondary Mirror Coating: Enhanced aluminum

Back focus:

	FA10	FA12	FA14	FA17
Back plate	6.25"	8.4"	9.8"	8.45"
Gemini	3.75"	5.75"	6.3" *	6"
TCF-S3i	1.95"	3.95"	4.4"	4.2"
Leo	5"	7.15"	9"	7.25"

	10 iDK	12.5 iDK	14.5 iDK	17 iDK
Back plate	10.85"	11.05"	11.05"	11.4"
Gemini	7.1"*	7.3"*	7.35" *	7"*
TCF-S3i	6.3"	6.5"	6.55"	6.2"

	12.5 iHW			
Back plate	7.4"			
Gemini	4.95"			

* assumes the Optec 4300 25mm extension tube is used between the Gemini and the back plate

Cooling fans: 12 VDC, center pin positive, 5.5 x 2.1 mm

Receiving the Telescope

Please inspect the shipping crate for any damage when you receive the telescope from the shipper. If any significant damage to the crate is visible (crushed corners, holes, water damage, etc.) you should immediately bring it to the attention of the delivery person and document the damage by taking images of it.

Once you have the box opened, carefully inspect the telescope for any damage and, if any should be found, document the damage with a photograph and immediately contact the shipping company and AG Optical Systems.

Initial Assembly

Very little assembly is required to prepare your AG Optical Systems astrograph for use.

Optec Focuser (standard)

You will need to attach the Optec TCF-S3i, Leo, or Gemini focuser to the back plate of the telescope. To do this, slide the focuser over the focuser adapter (already mounted to the back plate) and tighten the set screws at the base of the Optec focuser to secure the focuser in place. Take care to ensure the focuser is square to the back plate and securely mounted.

Optec Configuration

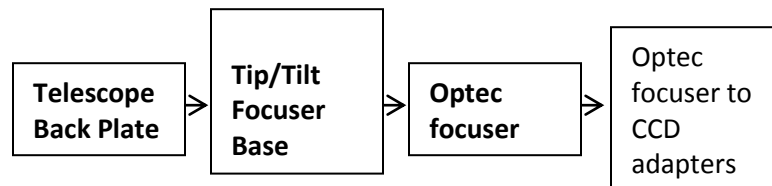

Items in **bold** type are supplied by AG Optical Systems with the Optec focuser option. The user will need to acquire the adapters required to mount their particular CCD camera to the Optec focuser.

Collimation

Precise collimation is critical to ensure the full potential of your AG Optical Systems astrograph is realized. Best results will be achieved when you use quality collimation tools and follow a systematic approach. Be patient and do not settle for anything less than “textbook” perfect collimation. While collimation tools will get you close to textbook collimation it is almost certain that you will need to tweak collimation by taking actual images and making slight adjustments to collimation of the primary and secondary mirrors.

Collimation is an iterative process where changes in collimation to one optical element will often necessitate a collimation adjustment on another optical element. Be patient, take notes, and mark the starting position of the collimation screws.

Imaging systems with larger chip cameras will be more challenging to collimate as any tilt in the system is more pronounced at the corners of the sensor. Fast optical systems have a small depth of focus (a F5 system is 1/4th that of a F10 system) so even small amounts of tilt may cause stars to have odd shapes towards the corners of a moderate to large imaging sensor. It is critical that you carefully focus prior to assessing the shapes of the stars across the field of view. It is often helpful to focus on a star that is about 1/2 way towards the corner of the image.

AG Optical Systems suggests you read many of the excellent online resources describing how to collimate a Cassegrain or Ritchey Chretien telescope. These resources provide a rich wealth of detailed theoretical and practical information that will enable you to achieve precise collimation of your AG Optical Systems telescope.

Although AG Optical Systems collimates each telescope prior to shipment, fine tuning of the collimation will almost always be required due to the uniqueness of each imaging train. To facilitate the collimation process, AG Optical Systems suggests you have the following collimation tools on-hand:

Useful Collimation Tools

- 2" laser collimator with spot and ring projection options
- 2" Cheshire sight tube
- Artificial star
- Focuser adapters to allow the use of 2" collimation tools
- 1/8" and 3/16" hex key wrenches

Collimation Process Overview

Below is a general overview of the collimation process. Detailed instructions follow in the subsequent section. **Please read the entire manual before attempting to adjust your telescope.** Always exercise caution when using a laser collimator. Keep in mind that collimation is an iterative process that requires patience and practice.

1. Place the telescope on a flat, stable surface.
2. **Mark the position of the primary and secondary collimation screws so you have a reference point to return to. A Sharpie mark can be placed on each screw along with an adjacent mark on the backplate so that you can return the screws to their starting position. Do not skip this step or you may regret it.**
3. Insert the proper combination of adapters into the focuser to allow the 2" collimation tools to be squarely seated in the focuser. Make sure the adapters are properly tightened and seated to ensure no tilt is introduced into the system.
4. Insert a quality 2" laser collimator ensuring that it is firmly seated against the face of the adapter. Turn on the laser and observe where the laser spot falls on the face of the secondary mirror. If the laser spot falls off to the side of the center spot, double check to make sure the laser is squarely seated and centered in the adapter. Also, double check your laser collimator to ensure that the laser beam axis and mechanical axis are coincident. You can check this by loosening the adapter and rotating the laser collimator (while making sure the laser collimator

- is firmly seated against the adapter). If the laser spot traces an arc it means that the laser collimator is not properly aligned. In this case, the laser collimator should be replaced.
5. If you are confident the laser collimation is properly aligned and sits squarely in your focuser, you can adjust the tip tilt plate to aim the laser spot squarely in the center of the secondary. AG Optical Systems spots the center of the secondary mirror to aid in this process. Before adjusting the tip tilt plate you may want to insert and remove the laser collimator a few times into the focuser adapter and observe how much the location of the laser spot on the secondary mirror moves. Tolerances in the adapter often allow the laser collimator's position in the adapter to vary so you may need to make an educated guess as to the best position.
 6. Use a quality 2" laser collimator with a spot projection to collimate the secondary mirror from the front of the scope until the laser beam folds back onto itself and the reflected spot lands precisely on the laser emitter.
 7. Insert the Cheshire sight tube into the focuser. Remove the primary baffle. Adjust primary collimation until the images of the secondary, primary, and corrector housing appear concentric.
 8. Refine secondary collimation: Point the telescope at a star and use a moderately high power (150x) quality eyepiece to view a defocused image of the star. An artificial star is ideal for this process. Defocus the image outside of focus and adjust the secondary collimation until the shadow of the secondary is centered in the diffraction pattern of the defocused star. Be sure to keep the image in the center of the field of view.
 9. Adjust primary collimation: Observe the diffraction pattern outside of focus to see if the diffraction rings are evenly illuminated and spaced around the circumference. Also, notice the small point of light at the center of the diffraction pattern (Poisson Spot). If the illumination is uneven and the diffraction rings are more compressed on one side make small adjustments to the primary collimation until even illumination and evenly spaced rings are visible. It helps to inch closer to focus as you dial-in collimation as the test becomes increasingly sensitive the closer you are to focus. You may need to tweak the secondary after making this adjustment. Collimation is an iterative process.
 10. If the Poisson Spot is not centered make small adjustments to the secondary to center the spot. You may need to collimate the primary mirror after an adjustment to the secondary has been made.
 11. On a clear night, aim the telescope at a star and take a carefully focused image. If the stars look good across the field of view the scope is well-collimated. If not, take a defocused image of the star approximately .5mm outside of focus. Ensure the star is centered in the field of view. If necessary, make fine adjustments (often <math><1/10</math> of a turn) to the secondary mirror until the shadow of the secondary mirror is perfectly concentric with the diffraction rings. If the rings of the out of focus diffraction pattern are brighter on one side of the diffraction pattern than on the other side and adjustments to the secondary mirror do not correct this, adjust the primary mirror collimation. Take notes to keep track of the adjustments you are making and the effect they are having on the defocused image. Collimation adjustments may require that you recenter the defocused star after the adjustment.
 12. Take an image (focused) and inspect the stars across the field of view. If the stars are round in the center but are not round in any corner(s) tilt may be present. Assess the tilt by using software or by measuring the relative change in focus from the center to the edge of the field of view. Make a small adjustment to tip/tilt plate based on your findings and take another image to assess the impact of the change. Take notes to keep track of the changes you make and the results you get. Only adjust tilt once you are certain the scope is well-collimated.

Detailed Collimation Process

Collimating an AG Optical Systems Convergent, Imaging Harmer Wynne, or Imaging Dall Kirkham telescope is accomplished by making adjustments to the secondary mirror cell, primary mirror cell, and the tip/tilt plate until the optical axis of both mirrors are coincident and co-axial with the mechanical axis of the telescope.

The key to successfully collimating your telescope is to use a systematic approach that involves making small collimation adjustments, assessing the results of the change, and then making subsequent adjustments to further refine the collimation of the astrograph. Once collimation is achieved, the system will hold collimation for long periods of time unless the OTA is subject to rough handling.

AG Optical Systems carefully aligns the mirrors on our test bench using an artificial star. After shipping, however, the collimation of the system should be checked and, if necessary, adjusted. Given variability in adapters, CCD cameras, and focusers you should expect to make fine collimation adjustments to dial-in the system for your unique combination of imaging train equipment.

Before adjusting the collimation and tip tilt screws you will want to mark them so that you can return the screws to their original positions. This is very helpful should you need to return collimation to a known point. A Sharpie mark on a screw along with an adjacent mark on the telescope is simple to do and will be useful. Rubbing alcohol can be used to remove the marks.

Adjusting the Secondary Mirror

Mark the secondary collimation screws prior to adjusting them.

The collimation of the secondary mirror is adjusted using spring-loaded collimation screws located near the face of the secondary hub. 1/8" and 3/16" hex key wrenches are required to adjust secondary collimation. It often is necessary to adjust multiple collimation screws to adjust the secondary in a certain direction. **Ensure that all three lock screws are loosened prior to making any adjustments.** Once collimation is achieved, the position of the secondary mirror can be locked into place using the lock screws. Do not over-tighten the lock screws... gently snug is good enough.

Only small adjustments (1/8 turn or less) should be necessary to precisely collimate the secondary.

A sticker is attached to the face of the secondary holder indicating the distance from the sky-side face of the center hub to the face of the secondary holder. Should you get the secondary significantly misaligned or need to disassemble the scope you can use the indicated distance to reestablish the spacing between the secondary and the primary mirrors.

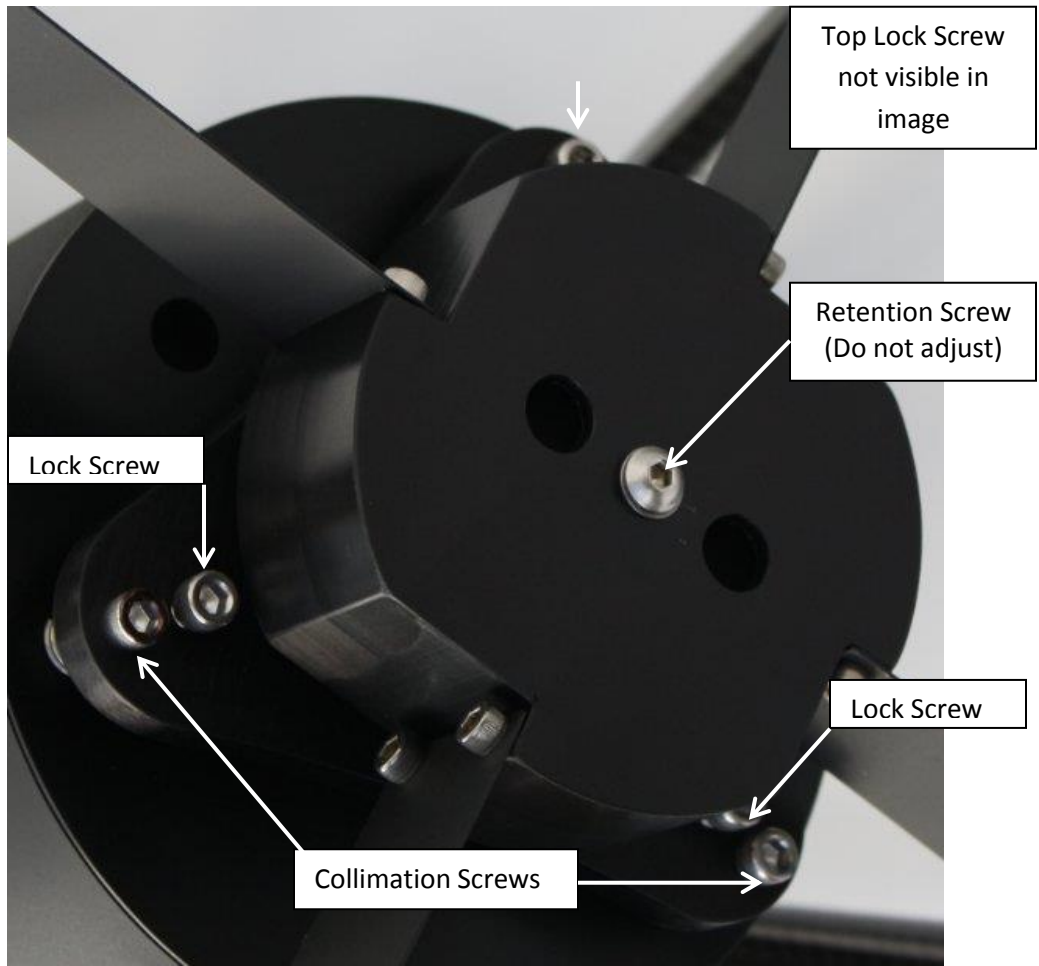
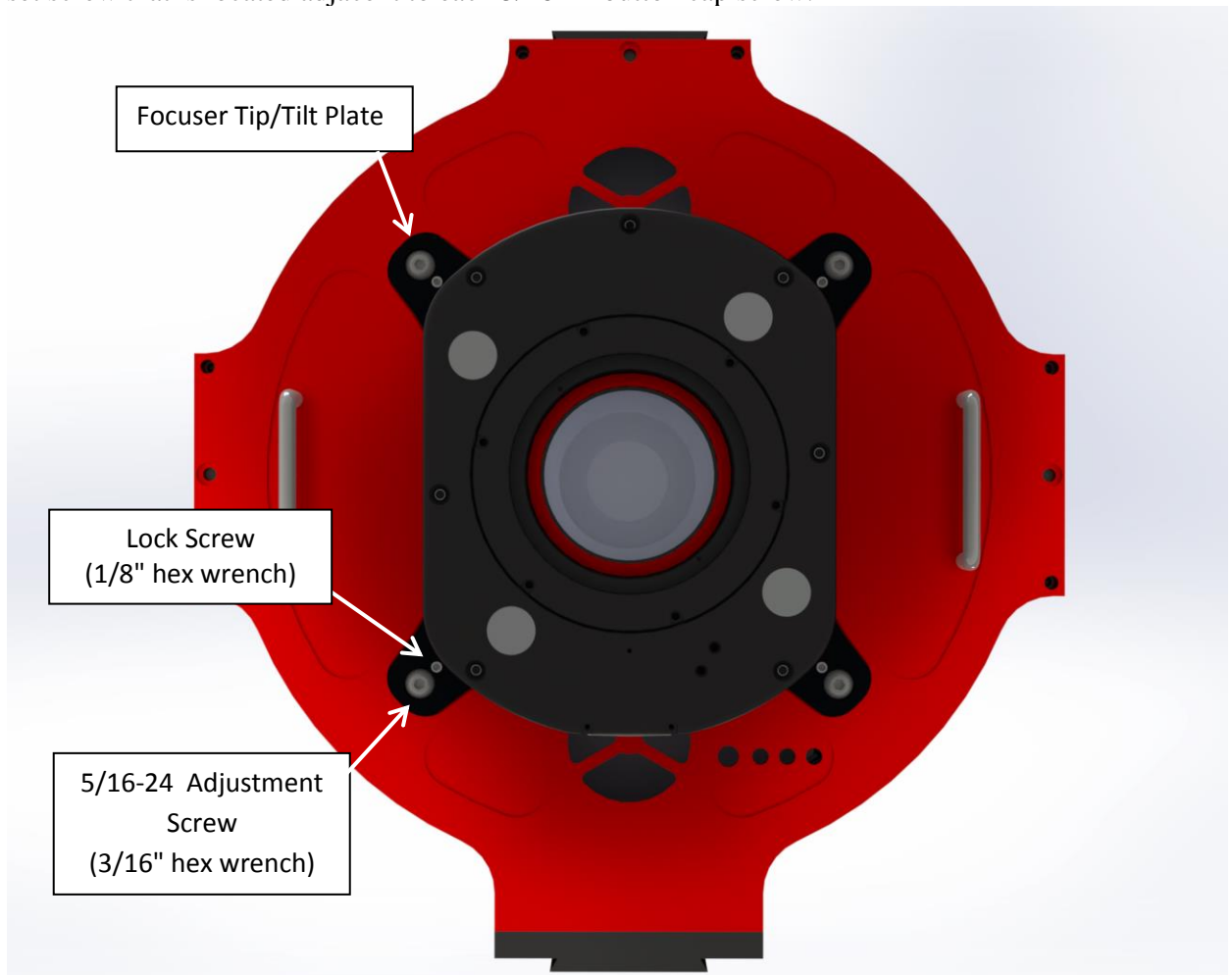

Figure 1 Secondary Hub with Collimation Screws

Initial Adjustment of the Secondary Mirror

Using a good quality 2" collimating laser with a spot projection is enough to obtain close but not necessarily perfect collimation of the secondary mirror. Final tweaking of the secondary mirror may be required using star images.

- 1) Insert the 2" laser collimator into your 2" focuser adapter and ensure the collimator is squarely seated against the adapter.
- 2) Observe where the laser spot falls on the secondary. If the laser spot is off center by more than 1 to 2mm and you are fully confident that the laser collimator is aligned properly and squarely seated in the focuser you can use the tip/tilt adjustments to adjust the focuser so that the laser spot hits dead center on the secondary.
- 3) The focuser tip/tilt plate is attached to the backplate using four 5/16-24 button cap screws. Spring washers are positioned under each corner of the tip/tilt plate allowing for a small adjustment range. AG Optical Systems carefully aligns the tip/tilt plate prior to shipping the telescope. However, an adjustment to the tip/tilt plate may be necessary if your imaging train has tilt present. It is very common to have some degree of tip/tilt present in an imaging train so it is possible you will need to make a tip/tilt adjustment. To do this, loosen the 1/4-20 set screw that is located adjacent to each 5/16-24 button cap screw.



- 4) Mark the tip tilt adjustment screws so you can return the tip tilt plate to its starting point if necessary.
- 5) Make a small adjustment to a 5/16-24 button cap screw and observe how the laser spot moves on the face of the secondary mirror. Continue making small adjustments until the laser spot hits the precise center of the secondary mirror. You may need to adjust two or more screws to move the laser spot in the desired direction. Only small adjustments should be necessary.
- 6) Once the laser spot is well-centered, snug up each of the 1/4-20 set screws to lock the tip/tilt plate.
- 7) Move to the front of the telescope and observe where the reflected laser spot falls on the face of the laser collimator. You will need to look down the primary baffle to observe this. You will most likely see two laser spots. One is the laser emitter and the other is the reflected laser spot. It is helpful to remove the primary baffle for the initial collimation of the primary and secondary mirrors. This is easily done by loosening the large, knurled lock ring located at the base of the primary baffle. Carefully grasp the lock ring and loosen it (counterclockwise) until it comes free. Then remove the primary baffle and lock ring. When reinstalling the primary baffle, be careful not to cross thread the lock ring. **Exercise caution working near the face of the primary mirror.**

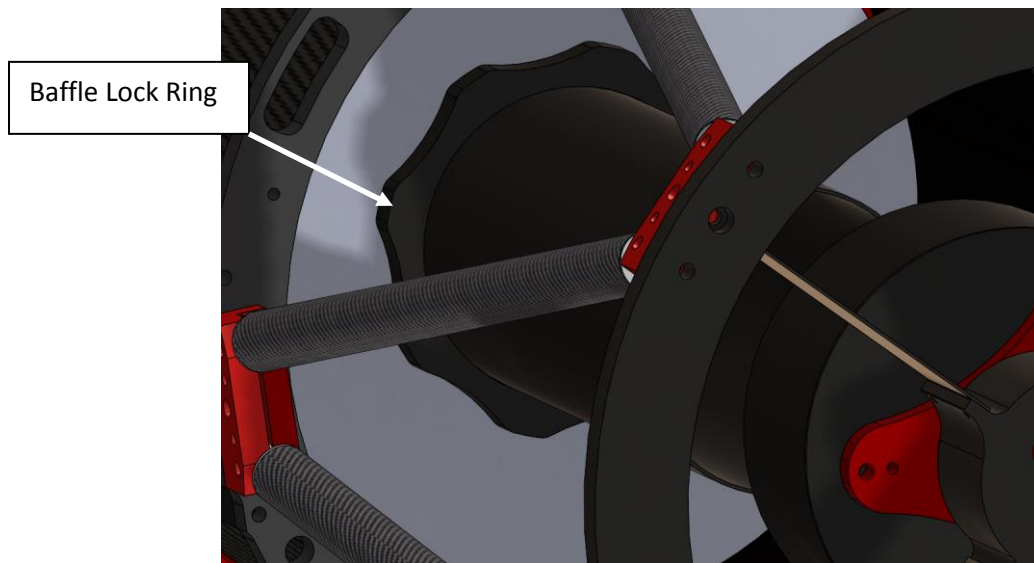

- 8) Mark the position of each secondary collimation screw prior to making any adjustments.
- 9) Ensure that the three secondary collimation lock screws are loose and then adjust the secondary collimation screws until the laser spots converge into a single spot. Once the two laser spots converge, gently snug the collimation lock screws. Only small collimation adjustments should be necessary.
- 10) Further refinement of the collimation will require observing a real or artificial star.

Initial Adjustment of the Primary Mirror

Insert the Cheshire sight tube into the focuser. Look through the sight hole and observe the concentricity of the secondary mirror, secondary baffle, primary mirror, and corrector housing. You will be observing actual and reflected images.

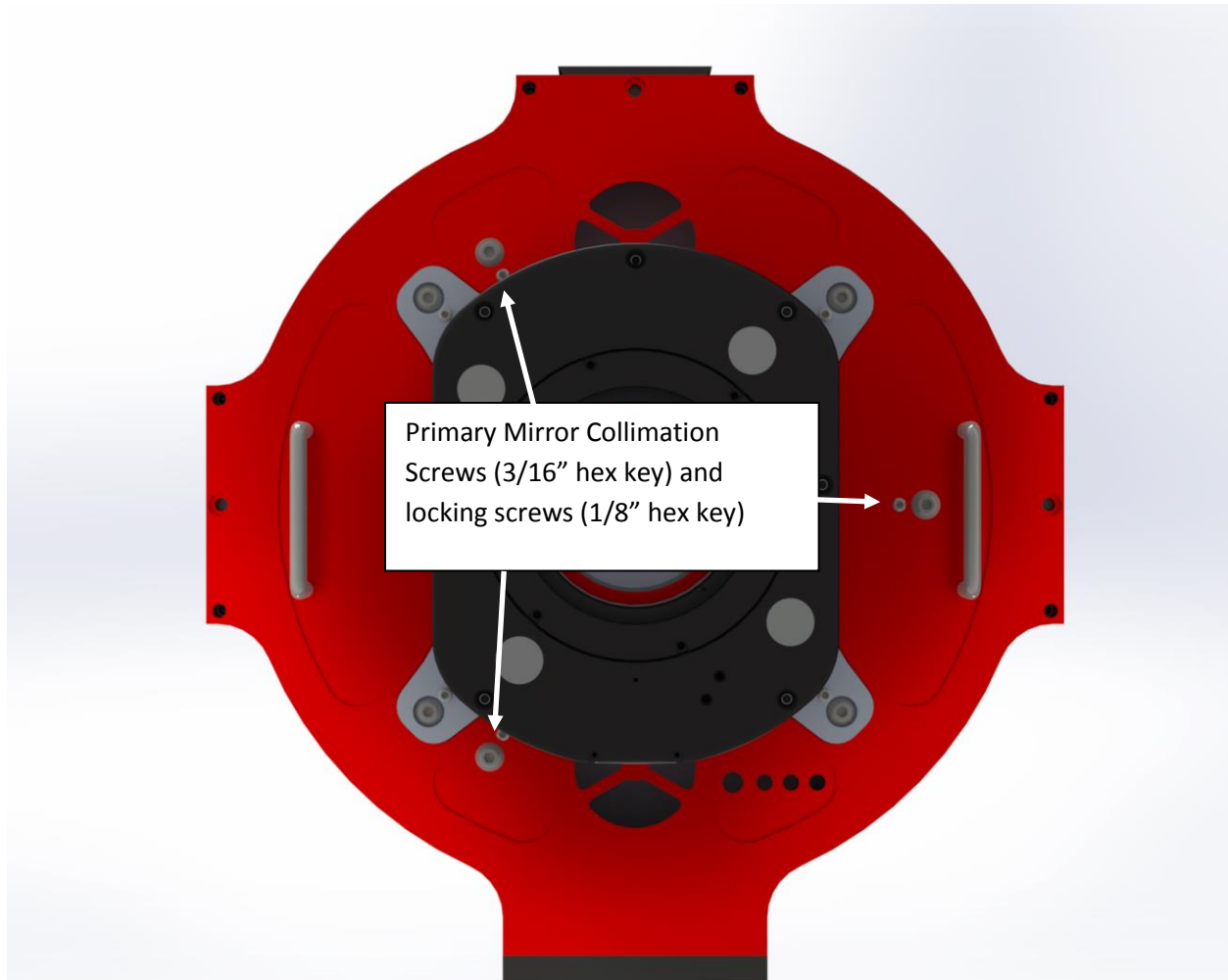

- 1) Loosen the three lock screws (set screws) and back them out a couple of turns.
- 2) Adjust one of the primary mirror collimation screws while peering through the Cheshire. Observe the effect the adjustment has on the view. Only small adjustments should be necessary. **It is helpful to place a piece of tape over the tip/tilt adjustment screws as it is easy to adjust the wrong screw.**
- 3) Adjust the primary in small increments until the view through the Cheshire presents concentric images as shown below. Notice the spider vanes align with the reflected images of the spider vanes. An image such as the one below will be achieved when the system is moderately well-collimated and the secondary is centered above the focuser.



It is also convenient to use a high quality laser collimator that projects a ring pattern. After the secondary has been collimated, the ring projection laser collimator can be used to adjust the collimation of the primary. The objective is to have the shadow of the secondary centered within the projected rings.

Centering Secondary Mirror

All AG Optical Systems Convergent, Imaging Harmer Wynne, and Imaging Dall Kirkham telescopes have a spherical secondary mirror that does not need to be precisely centered in the tube assembly for the astrograph to provide excellent correction over the entire field of view. However, a significantly decentered secondary mirror will make collimation more challenging and will cause uneven field illumination that may be problematic if a rotator is used. Keep in mind that any tilt in the focuser/adapters/laser collimator will be cause the laser spot to fall off center of the secondary mirror giving the perception that the secondary is physically decentered when it may not be. **Only adjust the spider centration if the spider is not physically centered in the front truss ring. AG Optical Systems centers the spider in the front truss ring when building the telescope but some adjustment may be necessary if the optics are removed to be recoated or cleaned.**

If the secondary is physically centered in the front truss ring but the laser spot is not projected on the center of the secondary, adjust the tip tilt plate as described above. If the secondary is not physically centered in the front truss ring, adjusting the centration of the secondary mirror is accomplished by loosening and tightening opposing pairs of the spider vane screws. Each spider vane is connected to the truss using a 10-32 button cap screw. A 1/8" hex key wrench is required to adjust the screw. Always loosen the opposite screw before tightening a spider vane screw or you may damage the

spider vane. It may be necessary to adjust all four screws if the direction of adjustment is not aligned with a spider vane pair. Be careful not to overtighten the screws. It is helpful to grasp the spider vane while the screw is tightened in order to prevent the vane from twisting. Gently snug is good enough.

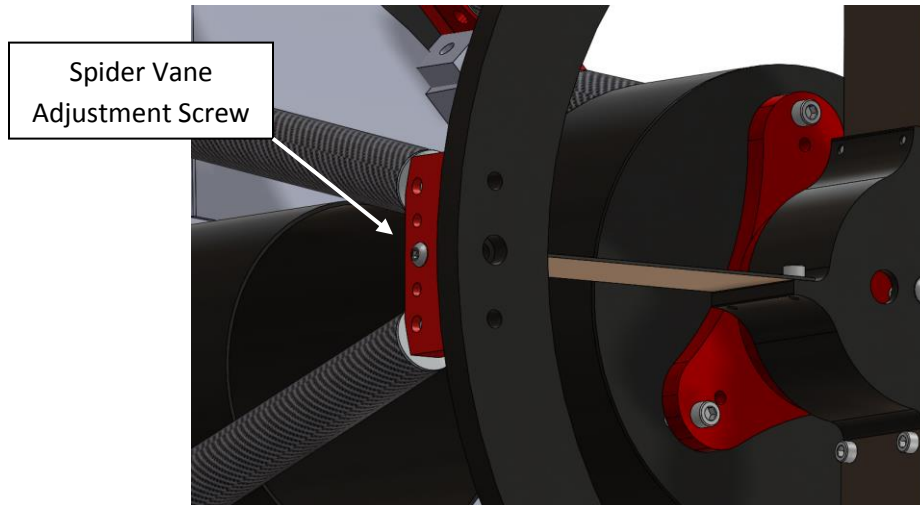

Refining Collimation

Refining collimation is an iterative process that involves making adjustments to the secondary mirror and primary mirror until the system is well collimated. Only small adjustments are necessary and a change in collimation to one mirror will often require a tweak in collimation to the other mirror.

The objective is to have a diffraction pattern with evenly illuminated and spaced diffraction rings with the Poisson Spot precisely centered in the diffraction pattern.

One a clear night with steady seeing point your telescope at a relatively bright star and center it in the field of view of your CCD camera or moderately high-power eyepiece (150x). An artificial star is a useful tool as it will allow you to refine the collimation of the telescope without requiring a clear night with good seeing . Defocus the image of the star outside of focus until the secondary shadow and diffraction pattern are clearly visible. **Ensure that the image of the star is centered in the field of view.** If the shadow of the secondary mirror is not precisely centered in the diffraction image of the star (see below) loosen the secondary mirror collimation lock screws and make a small adjustment to one of the secondary collimation screws, re-center the image of the defocused star in the field of view, and note how the defocused star image changed. Keep track of the adjustments you make in a notebook. Assuming the shadow of the secondary mirror is still not centered, make another small adjustment to a secondary collimation screw, re-center the image of the defocused star in the field of view, and note how the image changed. Continue making adjustments to the secondary collimation screws until the shadow of the secondary mirror is precisely centered in the diffraction image of the star. It is helpful to start with a moderately large defocused star image and progressively adjust the defocused image closer to focus as the secondary collimation adjustments become finer. Repeat this process until the star is nearly focused. Small adjustments to the secondary collimation screws on the order of 1/10 of a turn will produce a noticeable change. It may take some practice to get good at this process as judgment is required to determine when the shadow

is exactly centered. Your CCD software may have a circular pattern you can overlay onto the defocused image to help you assess the centration of the secondary shadow.

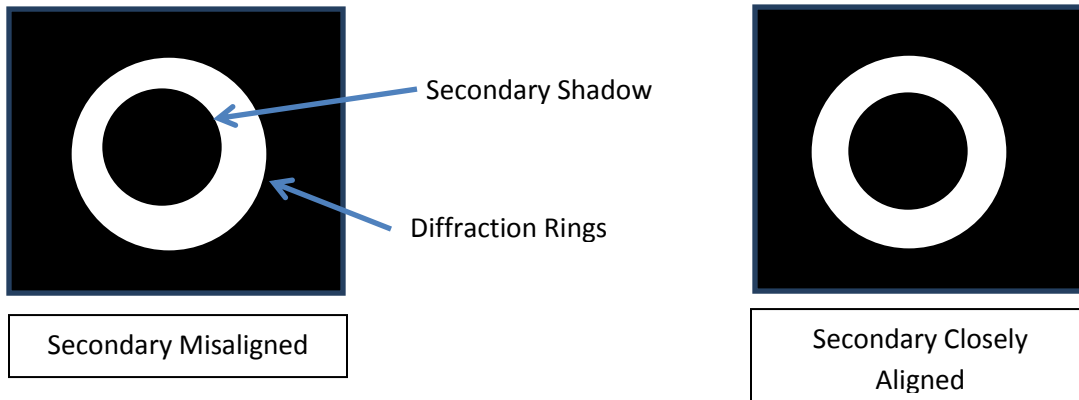

Once the secondary mirror has been aligned, carefully snug the lock screws. AG Optical Systems recommends that you tighten one lock screw until it just touches the secondary cell, repeat for the second lock screw and the third lock screw. Then, after all lock screws have been adjusted, gently snug up the first lock screw followed by the second lock screw and so on following the same pattern you used when initially tightening the lock screws. Please note that the lock screws do not need to be very tight in order to secure the secondary cell in place.... gently snug is good enough. Recheck the collimation of the secondary and adjust if necessary.

Refining Primary Collimation

After the secondary has been collimated observe the out of focus (outside of focus) star image. Look for uneven illumination around the outside edge of the diffraction pattern. Also, observe the centration of the Poisson Spot at the center of the defocused image. If any uneven illumination is present and the Poisson Spot is not precisely centered then the primary collimation should be slightly adjusted. An artificial star is useful as a first step prior to making final adjustments using actual star images.

If primary collimation is slightly off, the diffraction pattern will not be evenly illuminated and the Poisson Spot will not be centered. Make sure the primary collimation lock screws have been loosened. Make a slight adjustment to the primary collimation screw OPPOSITE the bright side of the diffraction pattern. Make sure you are outside of focus. Recenter the image and make a note of the change and the adjustment you made. Continue making adjustments to the primary collimation screws until even illumination is achieved. It is useful to move slightly closer to focus as collimation improves as you will be able to better discern the illumination of the diffraction pattern.

It may be necessary to make very small adjustments to the secondary collimation as improvements in the collimation of the primary may reveal that the secondary collimation is slightly off.

Once you have achieved an evenly illuminated and centered diffraction pattern carefully focus the telescope and take an image. Observe the shapes of the stars across the field of view. Critical collimation is necessary to achieve excellent results and it may take several attempts to dial-in the

system. It is helpful to focus on a star $\frac{1}{2}$ way towards the corner of the field of view especially with larger sensor CCD cameras.

Tip/Tilt Plate Adjustment

The focuser tip/tilt plate is attached to the backplate using four 5/16-24 button cap screws. Spring washers are positioned under each corner of the tip/tilt plate allowing for a small adjustment range.

AG Optical Systems carefully aligns the tip/tilt plate prior to shipping the telescope. However, an adjustment to the tip/tilt plate may be necessary if your imaging train has tilt present. It is very common to have some degree of tip/tilt present in an imaging train so it is possible you will need to make a tip/tilt adjustment.

To determine if tilt is present, take an image of a dense field of stars. Be very sure that the telescope has been well-collimated prior to making any adjustment to the tip/tilt plate. You can assess this by focusing on a star in the center of the field of view and confirming that the stars in the center of the field of view are round. If they are not, the secondary and/or primary is not well-collimated. If the stars in the center of the field of view are round, inspect the stars in the corners to see if they are satisfactorily round. If the stars appear to change shape across the field of view tilt is likely present in the imaging train.

A way to assess tilt is to use software such as CCD Inspector to determine the amount and direction of tilt present in an image.

You can also assess tilt by focusing on a star in the center of the field of view and making a note of the focuser position. One at a time focus on a star in each corner making a note of the position of the focuser when focus is achieved for each corner. Assess the focus change required to obtain sharp stars in each corner to determine the tilt present across the field of view. This will provide an indication of the direction of adjustment for the tip/tilt plate.

To emphasize, it is very important to have the primary and secondary mirrors well-collimated prior to assessing tilt in the system.

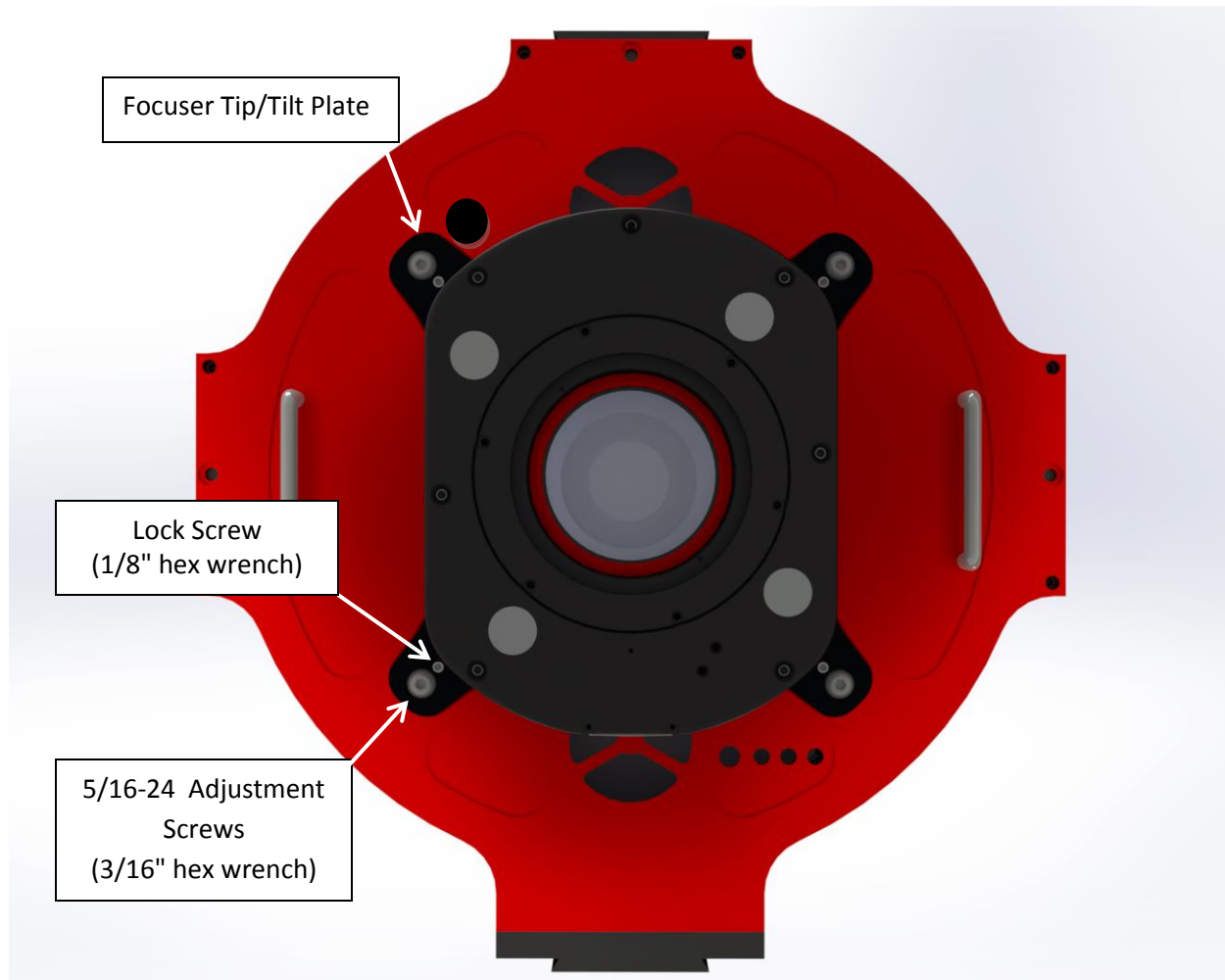

If your analysis indicates that tilt is present in the system then the focuser tip/tilt plate can be adjusted to zero out the tilt.

Prior to making an adjustment to the tip/tilt plate, loosen the four 1/4-20 set screws using a 1/8" hex wrench. The set screws can remain loose while you are adjusting the tip/tilt plate.

Adjustments to the tip/tilt plate are made by tightening/loosening the 5/16-24 button cap screws using a 3/16" hex wrench. Each screw has a small range of adjustment so it may be necessary to loosen/tighten opposing screws in pairs to ensure that the springs under each adjustment screw do not reach the end of their travel range

Note the orientation of your CCD camera and the direction of tilt that was present in the image relative to the CCD camera. Adjust the tip/tilt plate using a combination of the four adjustment screws to cancel out the tilt. Each complete turn of the adjustment screw equates to .042" of motion. Make a small adjustment (1/20 turn), write down the adjustment you made, take another image, and assess the change the adjustment had on the image. Repeat this process until the tilt is reduced to an acceptable level. Check collimate after each tip/tilt adjustment and adjust if necessary.

Tilt of just a few thousandths of an inch across the length of a CCD chip will affect the shapes of the stars across the field of view. Be patient and methodical while collimating the telescope. Larger CCD sensors will be more sensitive to tilt.

Once you have completed the tip/tilt adjustment, gently tighten the four 1/4-20 set screws against the back plate to lock the tip/tilt plate in place.

Collimation Summary

Collimation is an iterative process that requires a methodical, patient approach in order to achieve good results. Faster systems (like the F3.9 iHW and F5 Convergent Series) have stringent collimation requirements especially with larger CCD sensors. Take notes and mark the starting position of the adjustment screws.

Tips

- Use a good quality laser collimator that projects a point to collimate the secondary mirror. Confirm that the laser is properly aligned.
- Be sure to recheck the collimation of the secondary after making adjustments to the tip/tilt plate. Collimation is an iterative process.
- Ensure that the scope has had sufficient time to cool prior to attempting to precisely collimate the scope.
- Focus carefully as even a slight amount of defocus can significantly affect the shapes of stars.
- Don't give up until you achieve text book collimation. Do not over-tighten the collimation lock screws.... snug is good enough!

Care and Cleaning

Warm water or gentle household cleaners (such as Windex) may be used to clean the exterior of your AG Optical Systems astrograph. Paint thinners and other strong chemical solvents should never be used as they may cause damage to the finish of your astrograph.

WARNING

AG Optical Systems recommends that you **always** keep your AG Optical Systems astrograph covered when the telescope is exposed to direct sunlight. The black finish (paint or clear coated carbon fiber) rapidly absorbs heat which, in extreme cases, could cause damage to the paint and in any case causes undesirable heating of the telescope.

Cooling Fan Operation

Your AG Optical Systems astrograph is equipped with fans to decrease the time it takes the primary mirror to achieve thermal equilibrium with ambient air. These fans require 12 volt DC power that is supplied via the center pin positive 5.5 mm x 2.1 mm female connector located on the back plate of the telescope. The plug is identified with a round blue sticker.

The speed of the fans can be adjusted using the small black knob located on the back plate. AG Optical Systems recommends that you ramp the fans to their highest speed and then slow them to the speed you desire. Only a slight turn on the knob is required to adjust the speed of the fans.

AG Optical Systems Thermal Control System (option)

Please refer to the TCS Manual in the "Support" section of the AG Optical website for the latest TCS manual.

Introduction

The AG Optical Systems Thermal Control System (TCS) consists of:

- TCS Control Box
- AG Optical Systems Thermal Manager software application (Windows compatible)
- Primary mirror cooling fans
- Primary mirror heater
- Secondary mirror heater
- Primary mirror temperature sensor
- Secondary mirror temperature sensor
- Ambient temperature sensor
- cabling

The system is designed to maintain the temperature of the primary and secondary mirrors within a few degrees of ambient air temperature by automatically turning on and off the heating and cooling elements of the TCS according to parameters set by the user. Given the wide variability of factors affecting the thermal behavior of the telescope system, AG Optical System designed the TCS to be a simple but effective system that the user can easily monitor and adjust to achieve the best possible performance for their specific telescope system.

Software Installation

The TCS software installation file is located at the AG Optical Systems website under the “Support” tab. Please download the file to a location on your computer. **BEFORE** installing the software, connect the TCS Control Box to the computer using the supplied USB cable AND power cable. Be sure to power the Thermal Control Box using a high quality, regulated 12vdc power supply with at least 1.25 amps capacity. The USB connector and 12 VDC power port are located on the back plate side of the TCS Control Box.

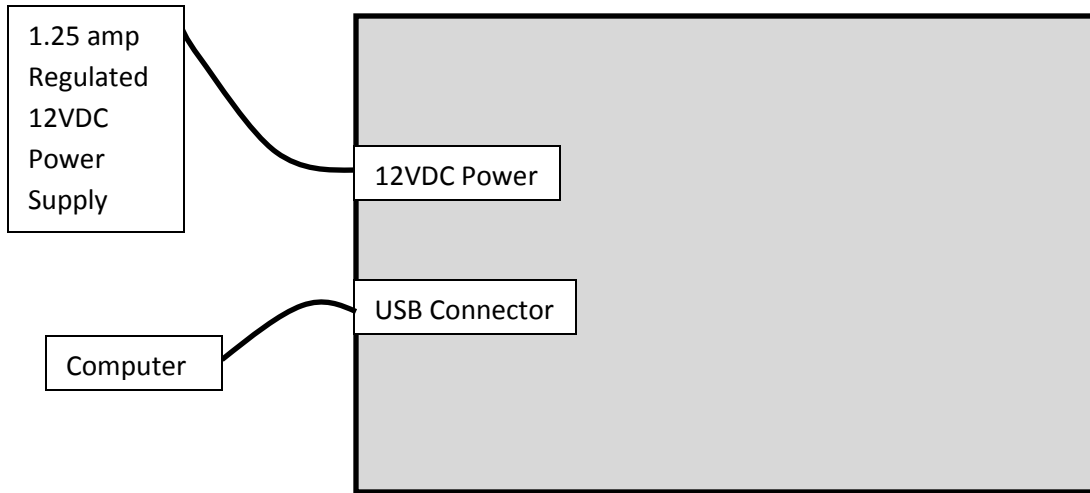

Wiring Diagram

Below is the wiring diagram describing how the various thermal control system elements are connected. A simple numbering and color scheme (1 through 6) is used to ensure each element is properly connected to the TCS Control Box.....Yellow connects to Yellow, Blue to Blue, etc. Some of the connection points are located on the telescope back plate.

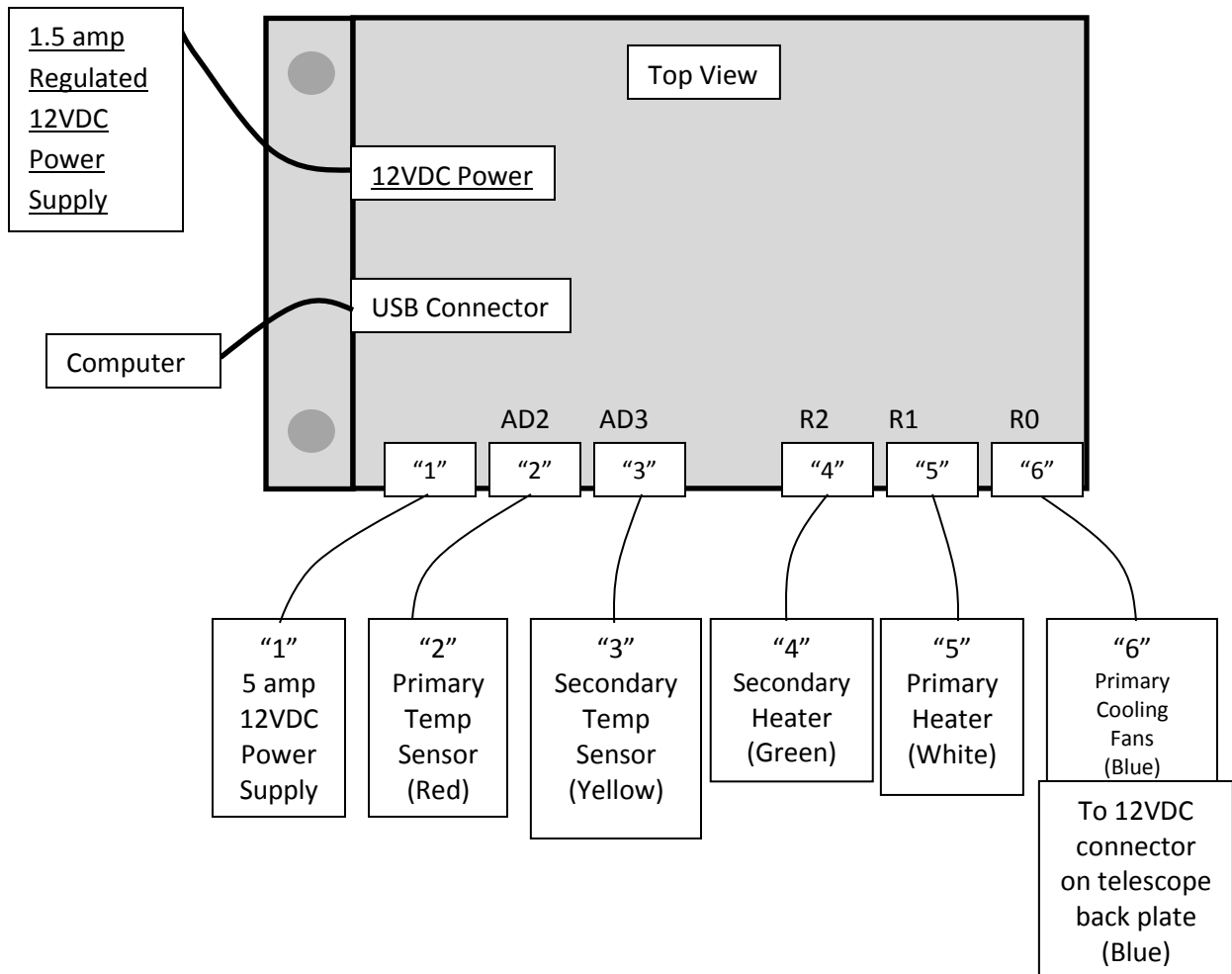

The other power connectors on the back plate are for the primary cooling fans and TCS temperature control elements (if applicable).

Note: It is suggested that you use two separate power supplies for the TCS Control Box. A quality, 12VDC regulated power supply capable of supplying at least 1.25 amps should be used for the power source for the TCS Control Box (underlined in the diagram above). A separate 12VDC power supply capable of supplying at least 2.5 amps should be used to power the cooling fans and heaters. Damage to the control board may occur if a non-regulated or non-switched power supply is used.

Operation

Please refer to the "AG Optical Systems Thermal Manager manual" at the following link:
<http://agoptical.com/customer-support/>

Shroud (option)

The AG Optical Systems Convergent shroud is hand crafted from a heavy Lycra material. The shroud will provide protection against stray light, help guard against dew formation, and reduce the amount of dust that enters the telescope.

Install the shroud by sliding it over the sky-side end of the telescope.



Note: If you need to wash the shroud, please hand wash in a sink. The shroud material can bleed color when it is washed so it is advisable to wash the shroud by itself and only when absolutely necessary.

Warranty

AG Optical Systems warrants the products it manufactures against defects in materials and workmanship for a period of two years for the original purchaser of the item. AG Optical Systems at its sole discretion will determine if the product has defective materials and/or workmanship. The customer will be responsible for paying all shipping costs associated with the return of the item and must contact AG Optical Systems prior to returning the item. If AG Optical Systems determines the item to be defective in materials and/or workmanship, AG Optical Systems will reimburse the customer's shipping costs and pay for shipping to return the item to the customer.

The terms of this warranty are void if the product is used for a purpose for which it was not designed (to include solar observations) or is subject to abuse beyond normal use. Items not manufactured by AG Optical Systems are covered by the terms of the original manufacturer.